

managing info *designed to the point of need*

labels tags electronic printers database link managers soabar solutions

Chemical Resistant White Printable Polyester Film **DURAFOL**[®]

Product 01-980

PRODUCT DESCRIPTION:

DURAFOL[®] – 01-980 50µ matt white top coated polyester offers superior chemical resistance combined with good humidity, elevated temperature and UV resistance. 01-980 top coating has been specifically designed to work in synergy with Ricoh B110CU thermal transfer ribbon for optimum chemical resistance performance. 01-980 is coated with P100 which exhibits excellent adhesion on a broad range of surfaces combined with very good chemical and elevated temperature resistance.

TYPICAL APPLICATIONS:

Chemical resistant labels

TYPICAL INDUSTRY SECTORS:

Automotive, chemical storage, electronic and pharmaceutical.

PERFORMANCE:

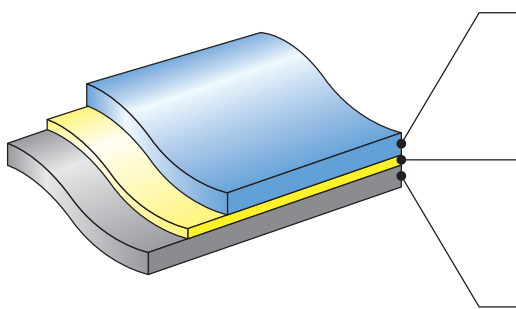

Facestock: 50µ matt white top coated polyester offers excellent chemical resistance combined with very good humidity, elevated temperature and UV resistance. Designed to accept conventional ink and Ricoh B110CU thermal transfer ribbon.

Adhesive: P100 High performance permanent acrylic adhesive has very good chemical, humidity, elevated temperature and UV resistance. Peel adhesion values are outstanding on most surfaces and will generally increase as a function of time and temperature. P100 offers a very good balance of high coat weight adhesive versus ease of conversion. Automotive approved.

Liner: LR09 is an 80gsm white release coated glassine liner. The glassine liner has been selected for flat bed and rotary die cutting performance.

GENERAL CHARACTERISTICS				
Properties	Typical Values		Unit of Measure	Test Method
Physical	Film		60µ ± 10%	FTM 12
	Adhesive		35gsm ± 10%	
	Liner		76µ ± 10%	
Peel Adhesion	Initial	24 Hours	N/25mm @ 23°C, 50% RH	FTM 1
Stainless Steel	16.7	24.3		
Glass	15.6	22.8		
Polypropylene	4.8	11.2		
Shear Resistance	>4000		Minutes	FTM 8
Dimensional Stability	Excellent		mm	FTM 14
Chemical Resistance	Excellent *			
Minimum Application Temperature	+4°C			
Service Temperature Range	-40°C to +149°C			
Outdoor Durability	Two years		Vertical exposure conditions	

* Heat and pressure settings on thermal transfer printer influences anchorage of Ricoh B110CU ribbon and therefore chemical resistance performance.

soabar 7 Ashville Way, Whetstone, Leicester LE8 6NU

t +44 (0)116 284 7000 f+44 (0)116 284 7001 Sales@soabar.co.uk

managing info *designed to the point of need*

labels tags electronic printers database link managers soabar solutions



PRINT PERFORMANCE

Test labels were thermal transfer printed with a Ricoh B110CU ribbon on a Zebra 110 Xi III Plus at temperature setting 25 and speed of 4inch/second.

Chemical resistance of printed image				
Chemical	Unit of measure	Test result	Test Method	Observations
IPA	100 rubs	5 grey scale	AATCC 8	No transfer of ribbon
Ethanol	100 rubs	5 grey scale	AATCC 8	No transfer of ribbon
Acetone	100 rubs	5 grey scale	AATCC 8	No transfer of ribbon
Xylene	100 rubs	5 grey scale	AATCC 8	No transfer of ribbon
MEK	100 rubs	5 grey scale	AATCC 8	No transfer of ribbon
White Spirit	100 rubs	5 grey scale	AATCC 8	No transfer of ribbon
SP95 Fuel	100 rubs	5 grey scale	AATCC 8	No transfer of ribbon
SP98 Fuel	100 rubs	5 grey scale	AATCC 8	No transfer of ribbon
Diesel	100 rubs	5 grey scale	AATCC 8	No transfer of ribbon
Brake Fluid	100 rubs	5 grey scale	AATCC 8	No transfer of ribbon
Toluene	100 rubs	5 grey scale	AATCC 8	No transfer of ribbon
Skydrol®	100 rubs	4.5 grey scale	AATCC 8	Minimal to no transfer of ribbon

Heat resistance of printed image				
Temperature	Unit of measure	Test result	Test Method	Observations
250°C	2 sec 3.6kgf/cm	5 grey scale	Madico MTM 0016	No transfer of ribbon

The amount of ribbon transfer is rated against the AATCC color chart; 1 to 5.
1 = high percentage print/colour transfer onto crocking cloth 5 = no print/colour transfer onto crocking cloth.

Humidity resistance of printed image				
Test Conditions	Test Duration	Test result	Test Method	Observations
60°C/95% RH	168 hours	5	Madico MTN0021	No discolouration or ribbon transfer

The amount of ribbon transfer is rated against the AATCC color chart; 1 to 5.
1 = high percentage print/film degradation 5 = no print/film colour degradation.

Ultra Violet resistance				
Test Condition	Test Duration	Test result	Test Method	Observations
8 hours UVA at 60°C	1000 hours	4.5	Madico MTN009	

Colour change rated against the AATCC color chart; 1 to 5.
1 = high percentage colour change 5 = no colour change.

Abrasion of printed image				
Performance criteria	Unit of measure	Test result	Test Method	Observations
Taber abrasion	CS10 500h load	40 cycles	ASTM D1044	Bar code and text readable

Note – Durafo[®] will only offer the above chemical resistance when printed with a Ricoh B110CU ribbon and an industrial thermal transfer printer. **The use of other ribbons is not recommended.** Small desktop printers are also not recommended due to insufficient pressure and head energy.

The representations of performance and suitability for use contained in this Data Sheet are meant only as a guide. Since only the user is aware of the specific conditions in which the product is to be used, it is the user's responsibility to determine whether the product is suitable for that intended use. Copyright 1995

soabar 7 Ashville Way, Whetstone, Leicester LE8 6NU

t +44 (0)116 284 7000 f+44 (0)116 284 7001 Sales@soabar.co.uk